

DYNAMIS

Batterien

DYNAMIS
LITHIUM-MN-LINE

Hohe Kapazität durch Lithium Mangan 9V Lithium-Mangan Dioxid (Li-MnO₂) Batterie

Unser **neuer Lithium Mangan 9Volt Block** bietet eine hohe Kapazität von 1300 mAh, eine konstante Entladespannung, sowie eine hohe Energiedichte und ist im erweiterten Temperaturbereich von -30° ~ +85°C einsetzbar.

Weitere Stärken unseres 9Volt Blocks sind sein sehr geringer Selbstentladungswert mit 10 Jahren Lagerfähigkeit. Auffällig ist außerdem sein niedriges Gewicht.

Ideale Einsatzgebiete sind u.a. Medizinische Geräte, Alarmanlagen in der Sicherheitstechnik, Rauchmelder, Gasmengen-Messer und -Warner, sonstige tragbare Meßgeräte, Steuerungen, Music/Audio-Anwendungen, sowie Industrieanwendungen etc.

Die Batterien sind ab Lager lieferbar.



Nennkapazität	1300 mAh
Nennspannung	9,0V
Max. Dauerentladestrom	120 mA
Max. Pulsentladestrom	400 mA
Empfohlene Lagertemperatur	+30°C max.
Zulässige Betriebstemperatur	-30°C ~ +85°C
Abmessungen L/T/H	26,0 x 17,2 x 48,8 mm
Gewicht	50 g

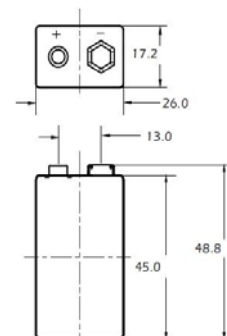

Fordern Sie ausführliche Informationen an.

DYNAMIS

LITHIUM-MN-LINE

LM 9V - P 1300 mAh Order no. 60.08024

9V Lithium-Manganese Dioxide (Li-MnO₂) Battery



Electrical characteristics

(typical values relative to cells stored for one year or less at +23°C max.)

Nominal capacity at 9,0mA +23°C 5,4V cut off. The capacity restored by cell varies according to current drain, temperature and cut off voltage).	1300 mAh
Nominal voltage	9,0V
Max. recommended continuous current	120 mA
Max. pulse current capability Pulse capability varies according to pulse characteristics (frequency and duration), temperature, cell history (storage conditions prior to usage) and the application's acceptable minimum voltage.	400 mA
storage (recommended) (for more severe conditions consult DYNAMIS)	+30°C max.
operating temperature range (Operation at temperature different from ambient may lead to reduced capacity and lower voltage plateau readings.)	-30°C ~ +85°C

Physical characteristics

length (max.)	26,0 mm
width	17,2 mm
height (max)	48,8 mm
typical weight	50 g

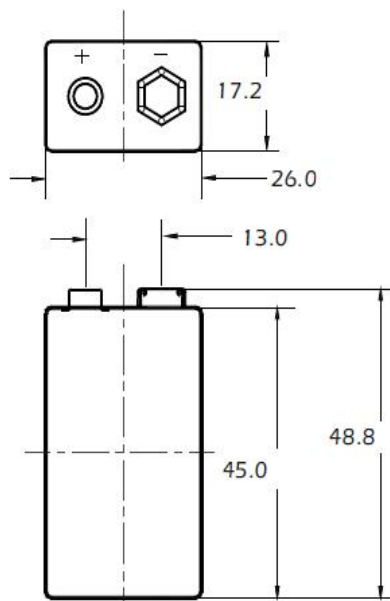

unit: mm

Key features

- High energy density
- Wide operating temperature range
- High pulse current capability
- Low self discharge rate (less than 0,16% per month at +23°C)
- Over 10 years service life
- Glass-to-Metall sealed

Warning

- Risk of fire and burns.
- Do not recharge, disassemble, heat over 100°C or incinerate.
- Do not mix fresh batteries with used Lithium batteries or other battery types.
- Do not try to recharge.

Main applications

Medical Devices
 Music/Audio Devices
 Smoking alarm
 Instrumentation
 Safety Devices
 Communication Devices
 Parking Meter etc.

Continuous Discharges at 23 °C (73 °F)

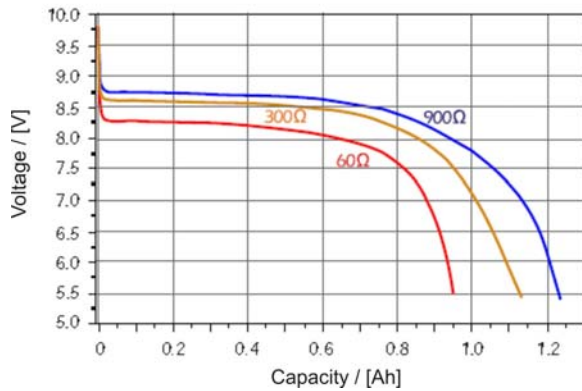

Continuous Discharges at various Temperatures (900 Ω)

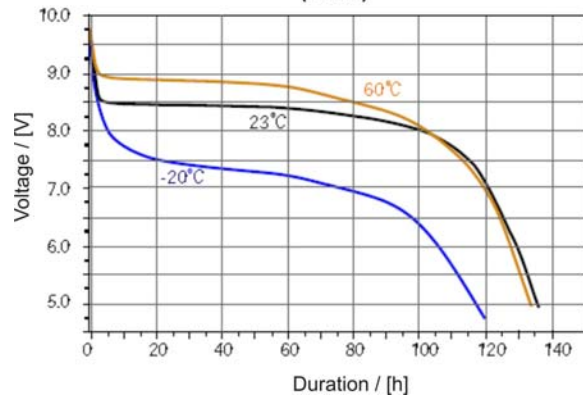

Short Circuit Behaviour Temperature and Current

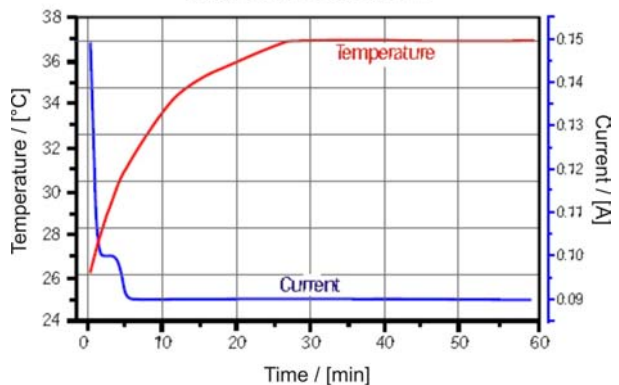

* The information (subject to change without notice) contained in this document is for reference only and should not be used as a basis for product guaranty or warranty. For applications other than those described here, please consult your nearest DYNAMIS Sales or Marketing Office or Distributors.